

RP-E-1702

Mito

Design: Tom Fereday

The Mito lighting series was designed to celebrate the natural beauty and character of raw materials. Minimal in design, Mito juxtaposes precision manufacturing techniques with natural hand finished timbers and stones to create a truly sculptural light.

Warm, indirect light flows across domed forms carefully crafted from natural materials. Modular in design, the Mito series may be configured at any angle and comes in a variety of both wall sconce and floor lamp configurations.

The Mito light. Pure materials, precision made.



Mito

DIMENSIONS

Mito

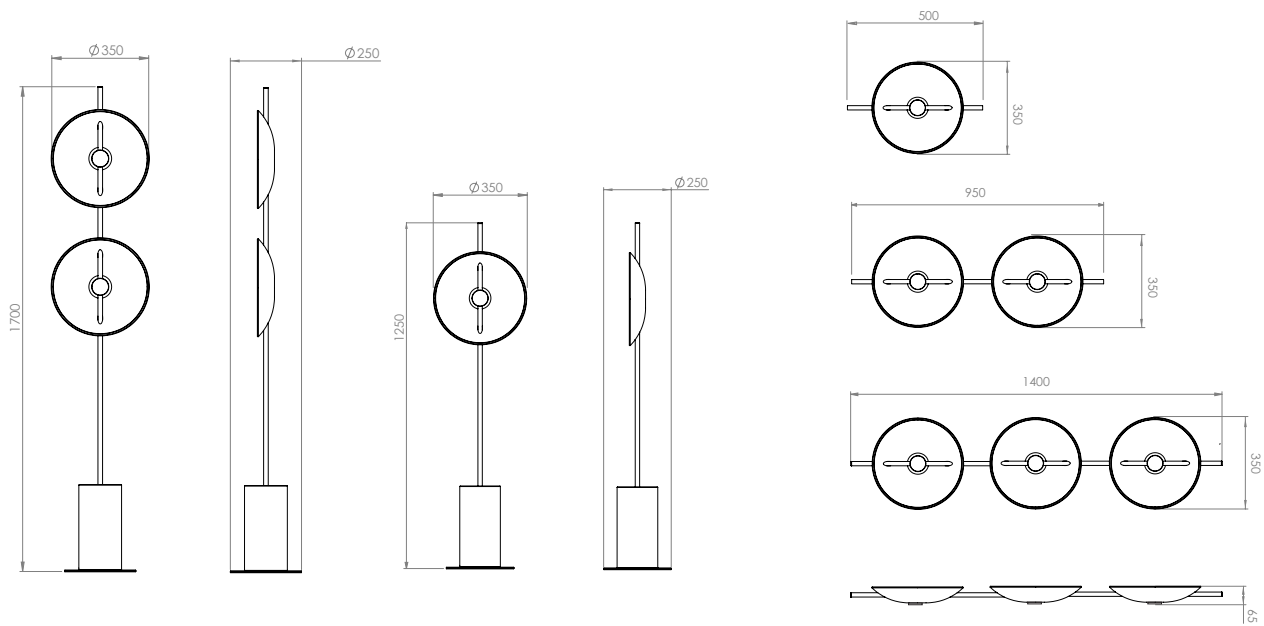

DIMENSIONS IN MILLIMETRES

FINISH SELECTION

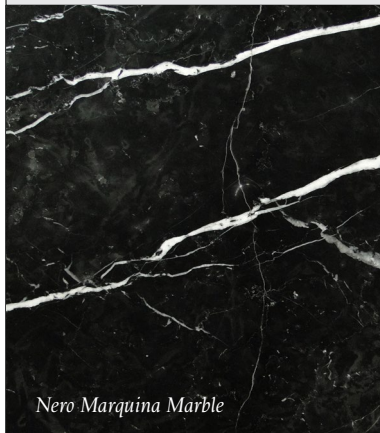

Nero Marquina Marble

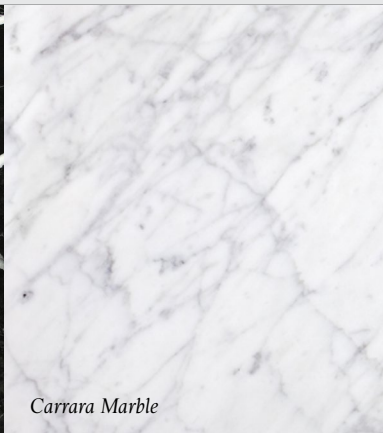

Carrara Marble



American Ash

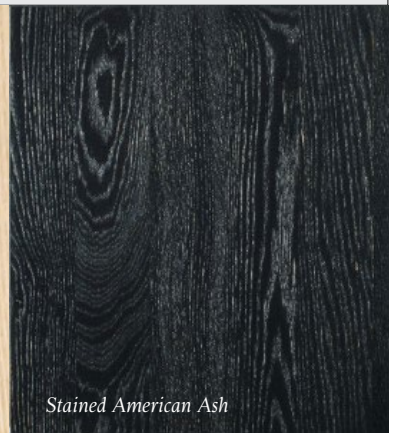

Stained American Ash

PRODUCT TECHNICAL SPECIFICATION

NAME:	MITO
DESIGN:	TOM FEREDAY
STYLE:	FLOOR LAMP & WALL SCONCE
MATERIAL:	NERO MARQUINA, CARRARA MARBLE, AMERICAN ASH, STAINED AMERICAN ASH, STEEL, ALUMINIUM
LIGHT SOURCE:	INTEGRATED TRIDONIC LED PER DISK // 3.9W // 400lm (MODULE) // 3000K // CRI90 // 100-240V DRIVER
DIMMING:	WALL SCONCE: NON DIM / SWITCH-DIM / DALI FLOOR LAMP: SWITCH-DIM
LAMP CORDSET:	2m BLACK TEXTILE FLEX // INLINE SWITCH DIMMER // DRIVER & PLUG



Tom Fereday develops products based on the principle of honest design - celebrating the manufacturing processes behind furniture and products, and designing from the inside out. He strives to create enduring designs that are meaningful to people and their environment.

Rakumba has been producing decorative lighting for the design industry since 1968. Collaborating with designers across a wide range of sectors from commercial to residential, we take pride in our bespoke service, attention to design detailing and ability to deliver on any scale of project.

©2017 Rakumba Lighting Pty Ltd